

Features:

- MX887D with 64 times faster sampling
- Omni polar (switches with N or S pole)
- 2.5 to 5.5 Volt Operation
- Simple Digital Output Interfacing
Open Drain
- Ultra Low Offset Canceling Amplifiers Provide Sensitive, Accurate, Stable Switching Points and Immunity to Mechanical Stress
- Solid State Circuitry
- Operating Temperature Range: -40°C to 100°C
- RoHS Compliant TSOT-23 3 Lead Package

General Description

The MX8871D integrated Hall-Effect switch targets battery operating voltages from 2.5V to 5.5V. On-chip power management circuitry reduces the effective average current to just 125µA at 3.0 V_{SUPPLY}.

The switch output will turn “on” when either a north or south magnetic pole is applied. The absence of a magnetic field will turn the switch into a high impedance “off” state.

Ordering Information

Part No.	Description	Qty
MX8871DHTTR	TSOT-23 3L Tape & Reel	3000

Applications:

- White Goods
- Automotive
- Security Systems
- High Reliability Reed Switch Replacement

Functional Block Diagram

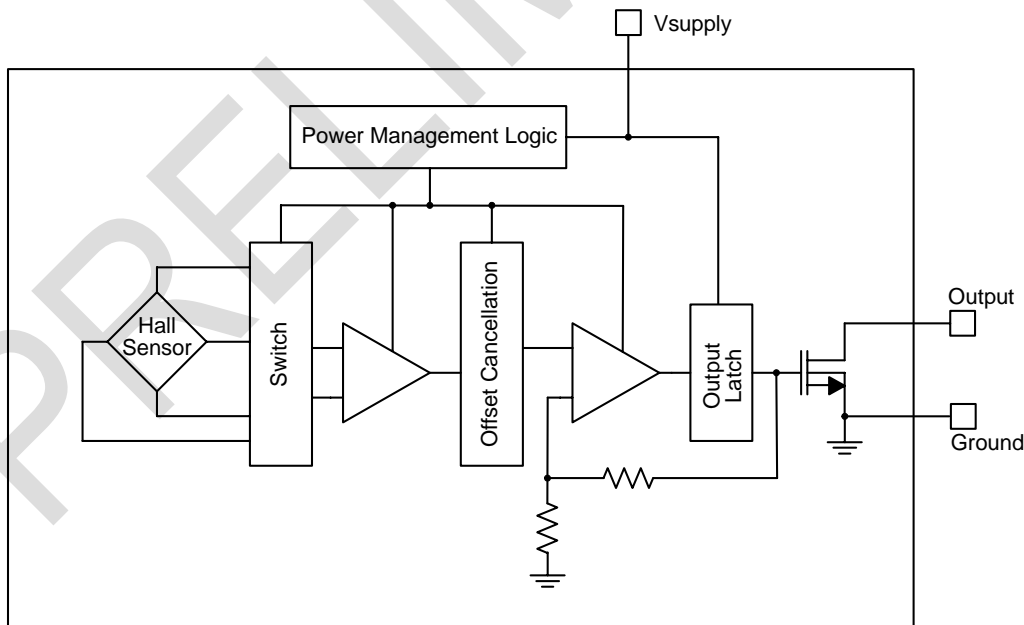

Pin Description

Pin No.	Pin Name	Description
1	VSUPPLY	2.5 to 5.5 Volt
2	OUT	Open Drain N-Channel FET
3	GROUND	Ground

Circuit Description

The MX8871D Hall-Effect Switch consists of a Hall element, small signal amplifier, latch, and n-channel open drain MOSFET driver. Offset cancellation rejects errors in signal stages and the influence of mechanical stress on the Hall element. This technique together with a precision threshold generator and comparator produce highly accurate magnetic switch points. The Hall element is activated for a fraction of an operating cycle, then latched in that sample state for the remainder of the period. By using this technique, reduced power consumption is achieved.

Electrical Characteristics

Over operating voltage and temperature range unless otherwise noted.

Parameter	Condition	Min	Typ	Max	Unit
Supply Voltage		2.5		5.5	V
Output Leakage Current	VOUT = 5.5V, BRPN < B < BRPS		<1.0	1.0	μA
Output On Voltage	IOUT = 1mA, VDD = 3.0V		50	100	mV
Awake Time				80	μS
Period				1.2	mS
Duty Cycle			6		%
Supply Current	Awake (enabled)			2.0	mA
	Asleep (disabled)			8.0	μA
	Average (Calculated)		125		μA
ESD	Human Body Model	2			kV

- Notes: 1. Operating and release points will vary with supply voltage.
 2. BOPX = operating point (output turns ON); BRPX = release point (output turns OFF).
 3. Typical Data is at TA = 25°C and VSUPPLY = 3.0V.

Magnetic Characteristics

Over operating voltage and temperature range unless otherwise noted.

Parameter	Symbol	Condition	Min	Typ	Max	Unit
Operating Points	BOPS	South pole to branded side			60	G
	BOPN	North pole to branded side	-60			G
Release Points	BRPS	South pole to branded side	6			G
	BRPN	North pole to branded side			-6	G
Hysteresis	BHYS	BOPX – BRPX		5		G

- Notes: 1. As use here, negative flux densities are defined as less than zero (algebraic convention) and -50G is less than +10G.
 2. BOPX = operating point (output turns ON); BRPX = release point (output turns OFF).
 3. Typical Data is at TA = 25°C and VSUPPLY = 3.0V.

TSOT23 - 3 LEAD

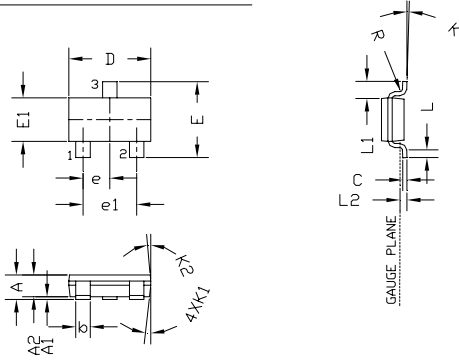

3. PACKAGE TOP MAY BE SMALLER THAN PACKAGE BOTTOM. DIMENSIONS D AND E1 ARE DETERMINED AT THE OUTERMOST EXTREME OF THE PLASTIC BODY EXCLUDING MOLD FLASH, TIE BAR BURRS, GATE BURRS AND INTERLEAD FLASH, BUT INCLUDING ANY MISMATCH BETWEEN TOP AND BOTTOM OF THE PLASTIC BODY.
2. DIMENSION "E" DOES NOT INCLUDE INTER-LEAD FLASH OR PROTRUSIONS. INTER-LEAD FLASH AND PROTRUSION SHALL NOT EXCEED .006" (0.15MM) PER SIDE.
1. DIMENSION "D" DOES NOT INCLUDE MOLD FLASH, PROTRUSIONS, OR GATE BURRS. MOLD FLASH, PROTRUSIONS AND GATE BURRS SHALL NOT EXCEED .004 IN. (0.10MM) PER SIDE.

NOTES: (UNLESS OTHERWISE SPECIFIED)

DIM.	DIMENSIONS					
	INCH			MILLIMETER		
	MIN.	NOM.	MAX.	MIN.	NOM.	MAX.
A	0.030	-	0.035	0.75	-	0.90
A1	0.000	-	0.004	0.00	-	0.10
A2	0.028	0.030	0.031	0.70	0.75	0.80
b	0.014	-	0.020	0.35	-	0.51
c	0.004	-	0.010	0.10	-	0.25
D	0.110	0.114	0.118	2.80	2.90	3.00
E	0.102	0.110	0.118	2.60	2.80	3.00
E1	0.059	0.063	0.067	1.50	1.60	1.70
e	0.0374 BSC			0.95 BSC		
e1	0.0748 BSC			1.90 BSC		
L	0.015	-	-	0.37	-	-
L1	0.0236 REF			0.60 REF		
L2	0.0098 BSC			0.25 BSC		
y	-	-	0.004	-	-	0.10
R	0.004	-	-	0.10	-	-
K	0°	-	8°	0°	-	8°
K1	7° NOM			7° NOM		
K2	5° NOM			5° NOM		

IXYS Corporation makes no representations or warranties with respect to the accuracy or completeness of the contents of this publication and reserves the right to make changes to specifications and product descriptions at any time without notice. Neither circuit patent licenses nor indemnity are expressed or implied. Except as set forth in IXYS' Standard Terms and Conditions of Sale, IXYS Corporation assumes no liability whatsoever, and disclaims any expressed or implied warranty, relating to its products including, but not limited to, the implied warranty of merchantability, fitness for a particular purpose, or infringement of any intellectual property right.

IXYS Corporation

3540 Bassett Street
Santa Clara, CA 925054
Tel: 1-408-982-0700
Fax: 1-408-496-0670
e-mail:sales@ixys.net

Micronix**An IXYS Company**

145 Columbia
Aliso Viejo, CA 92656-1490
Tel: 1-949-831-4622
Fax: 1-949-831-4628

SALES OFFICES AMERICAS**Eastern Region**

[Eastern North America, Mexico, South America]
IXYS Corporation
Beverly, MA
Tel: 508-528-6883
Fax: 508-528-4562
wgh@ixys.net

Central Region

[Central North America]
IXYS Corporation
Greensburg, PA
Tel: 724-836-8530
Fax: 724-836-8540
neil.lejeune@westcode.com

Western Region

[Western North America]
IXYS Corporation
Solana Beach, CA
Tel: 858-792-1101
slodor@ix.netcom.com

SALES OFFICES EUROPE**European Headquarters**

IXYS Semiconductor GMBH
Edisonstrasse 15
D- 68623 Lampertheim
Germany
Tel: 49-6206-503203
Fax: 49-6206-503286
marcom@ixys.de

United Kingdom

IXYS Semiconductor Limited
Langley Park Way
Langley Park
Chippenham
Wiltshire SN 15 1GE - England
Tel: 44 1249 444524
Fax: 44 1249 659448
sales@ixys.co.uk

SALES OFFICES ASIA / PACIFIC**Asian Headquarters**

IXYS
Room 1016, Chia-Hsin, Bldg II,
10F, No. 96, Sec. 2
Chung Shan North Road
Taipei, Taiwan R.O.C.
Tel: 886-2-2523-6368
Fax: 886-2-2523-6368
bradley.green@ixys.co.uk
Jhong@clare.com

Check the IXYS Website for the local sales office nearest you. (www.ixys.com)

<http://www.claremicronix.com>

IXYS cannot assume responsibility for use of any circuitry other than circuitry entirely embodied in this IXYS product. No circuit patent licenses nor indemnity are expressed or implied. IXYS reserves the right to change the specification and circuitry, without notice at any time. The products described in this document are not intended for use in medical implantation or other direct life support applications where malfunction may result in direct physical harm, injury or death to a person.

Specification: MX8871D
©Copyright 2007, IXYS Corporation
All rights reserved. Printed in USA.