

Features:

- Multiple Color Input Formats (CIE XYZ, Yxy, Yu' v', and RGB)
- 3 Channel Analog Interface to Color Sensor (X,Y and Z Channels)
- 3 Channel 12-bit PWM Output (Red, Green, Blue LED Channels)
- I²C Serial Interface
- Optional External Push-Button Interface
- Color Set Point Calibration to System Measurements
- Internal Clock Generator & Voltage Reference
- Error Flag Output
- Passive External Components
- Mixed Signal CMOS Technology
- 5V Digital and Analog Supply Voltages
- -40°C to +85°C Operating Range
- RoHS Compliant 24 Lead SOIC Package

Ordering Information

Part No.	Description	Qty
JDJ82200-00	SOIC-24 Tube	31
JDJ82241-00	SOIC-24 Tape & Reel	

General Description

The MXJDJ822 is an optical feedback controller for LED based lighting systems. These systems typically consist of red, green and blue LED's, LED drivers, a tri-color photosensor, and the MXJDJ822 feedback controller.

The MXJDJ822 processes color information from the photosensor and adjusts the red, green and blue LED drivers to achieve the desired color. Through the feedback control of the MXJDJ822 an LED array will maintain its color over time and temperature.

The desired color from the light output of the LED array is user programmable by simply writing the color coordinates from the CIE color space into the MXJDJ822 through the I²C serial interface.

The LED drivers are controlled by PWM signals from the MXJDJ822. These signals determine the on-time durations of the red, green and blue LED's. On-time durations are continuously adjusted in real-time to match the light output of the LED array to the desired color programmed into the MXJDJ822.

Functional Block Diagram

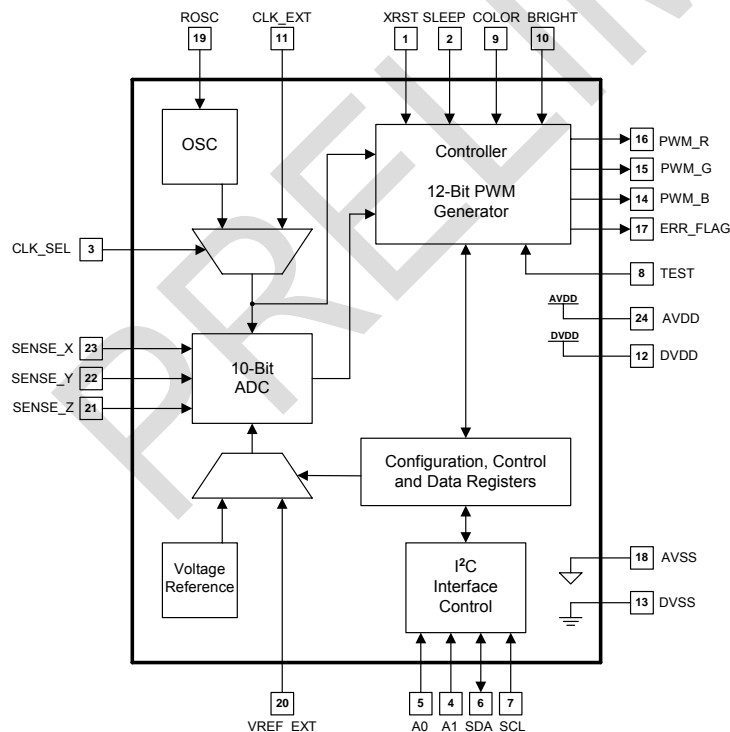

Pin Configuration

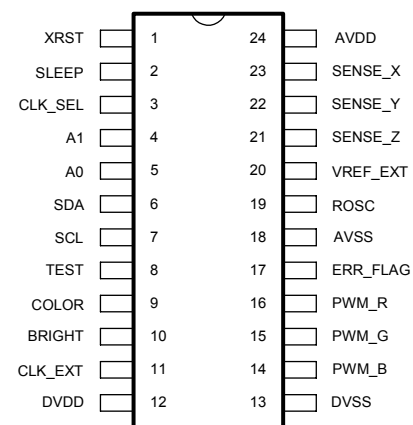

Top View
SOIC-24

Pin Description

Pin No.	Pin Name	Description
1	XRST	Global, asynchronous, active-low system reset.
2	SLEEP	Puts the device into sleep mode when driven high.
3	CLK_SEL	Selects internal or external clock modes. Internal clock mode is selected when CLK_SEL=0. External clock mode is selected when CLK_SEL=1.
4, 5	A1, A0	Defines the lower two bits of the I ² C slave address. A1(MSB), A0(LSB).
6	SDA	I ² C Data I/O
7	SCL	I ² C Clock
8	TEST	Must be connected to digital ground, (DVSS).
9, 10	COLOR, BRIGHT	Color and Bright interface pins. Driving the COLOR pin high with the Bright pin low changes the color hue. With the COLOR pin remaining high and the Bright pin transitioning high then returning low, the direction of color hue change is reversed. Driving the BRIGHT pin high with the COLOR pin low will increase or decrease brightness depending upon direction. With the BRIGHT pin remaining high and the COLOR pin transitioning high then returning low, the brightness direction is reversed.
11	CLK_EXT	External Clock input pin. Use when CLK_SEL=1.
12	DVDD	Digital Positive Supply
13	DVSS	Digital Ground
16, 15, 14	PWM_R, PWM_G, PWM_B	Red, Green, and Blue PWM output signals to the external LED drivers. These pins control the on-time duration of the LED's, and are software configurable to support either active high or active low enable inputs at the LED driver.
17	ERR_FLAG	A logic high level is presented at the error flag output pin when an error condition is detected. The error type can be determined by reading the ERROR register.
18	AVSS	Analog Ground
19	ROSC	A 68kΩ precision 1% resistor is connected from the ROSC to AVSS pin for use by the internal oscillator. In external clock mode, ROSC can be left unconnected.
20	VREF_EXT	The VREF_EXT pin is an analog input pin, which provides an external reference voltage for the ADC. Typically, the internal reference generator is used to operate the ADC. However, in specific application conditions an external reference may be required. The voltage reference source is determined by setting the appropriate bit of the configuration register.
23, 22, 21	SENSE_X, SENSE_Y, SENSE_Z	The SENSE_X, SENSE_Y, and SENSE_Z pins are analog input pins which are connected to the X-channel, Y-channel, and Z-channel outputs of the photosensor. An averaging filter is placed between the photosensor outputs and the SENSE input pins. The filter is typically a 68kΩ - 1μF single-pole low pass filter.
24	AVDD	Analog Positive Supply

SOIC-24 Package Dimensions

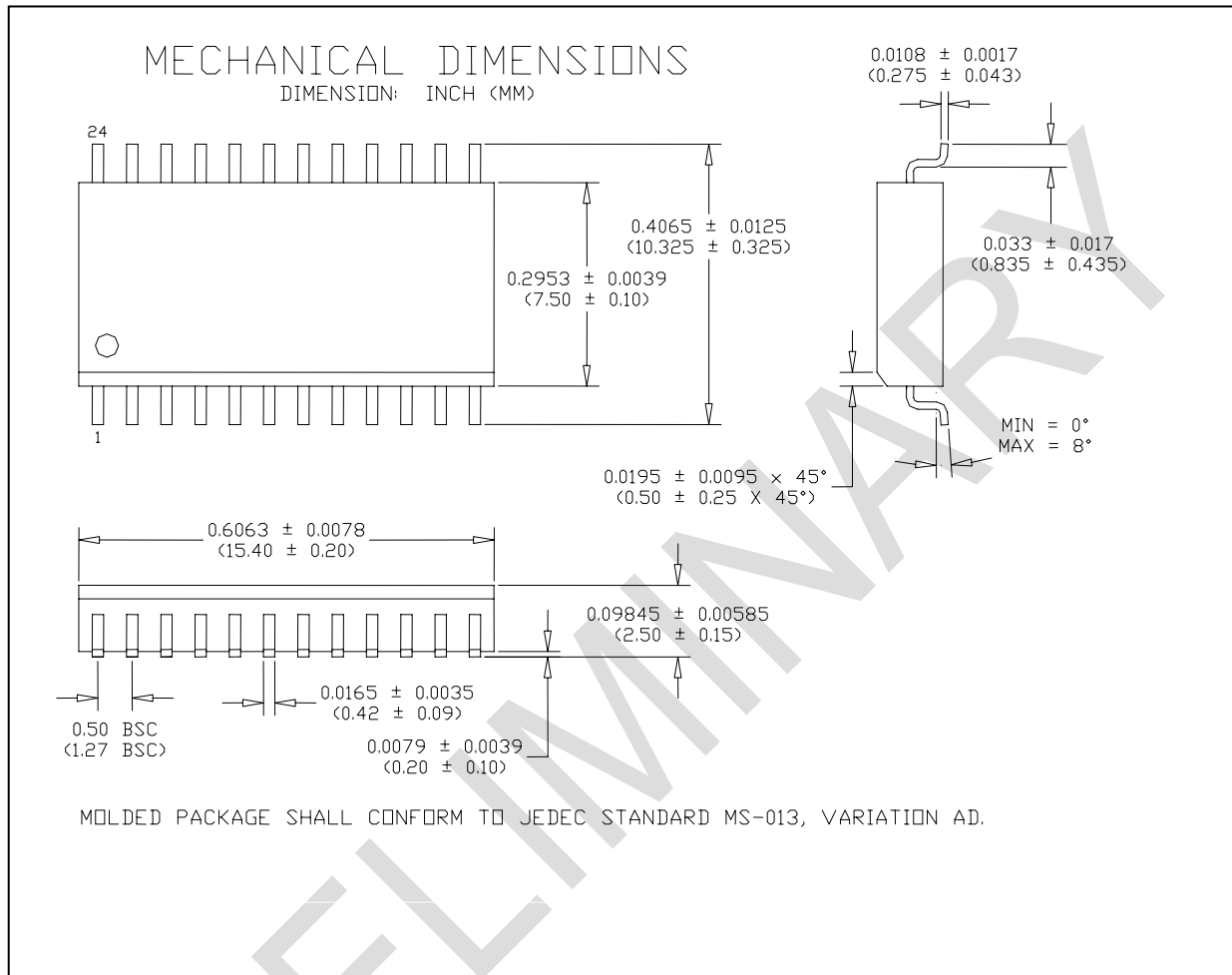

IXYS Corporation makes no representations or warranties with respect to the accuracy or completeness of the contents of this publication and reserves the right to make changes to specifications and product descriptions at any time without notice. Neither circuit patent licenses nor indemnity are expressed or implied. Except as set forth in IXYS' Standard Terms and Conditions of Sale, IXYS Corporation assumes no liability whatsoever, and disclaims any expressed or implied warranty, relating to its products including, but not limited to, the implied warranty of merchantability, fitness for a particular purpose, or infringement of any intellectual property right.

IXYS Corporation

3540 Bassett Street
Santa Clara, CA 925054
Tel: 1-408-892-0700
Fax: 1-408-496-0670
e-mail:sales@ixys.net

SALES OFFICES AMERICAS**Eastern Region**

[AL, AR, CT, DC, FL, GA, IA, IL, IN, KS, KY, LA, MA,
MD, ME, MI, MN, MO, MS, NC, ND, NE, NH, NJ, NY,
OH, OK, PA, RI, SC, SD, TN, TX, VA, VT, WI, WV,
Americas: Canada, Brazil]

IXYS

Beverly, MA

Tel: 1-978-524-6756

Fax:

w.hafner@ixys.net**Western Region**

[AK, AZ, CA, CO, HI, ID, MT, NM, NV,
OR, UT, WA, WY, Americas: Canada, Mexico]

IXYS

3540 Bassett Street

Santa Clara, CA 95054

Tel: 1-408-982-4353

Fax: 1-408-496-0670

EUROPE**European Headquarters**

IXYS Semiconductor GMBH
Edisonstrasse 15
D- 68623 Lampertheim
Germany
Tel : +49-6206-503203
Fax - +49-6206-503286

SALES OFFICES**France**

Eurocomposant
144, Av. J. Kessel
F-78960 Voisins-le-Bretonneux,
France
Tel : +33-130-649515
Fax : +33-130-436827

Germany

IXYS Semiconductor GMBH
Edisonstrasse 15
D- 68623 Lampertheim
Germany
Tel : +49-6206-503203
Fax - +49-6206-503286

Italy

IXYS
Via C. Colombo 10/A
I-20066 Melzo (Milano)
Tel: +39-02-95737160
Fax: +39-02-95738829

Sweden

IXYS Sales
Comptronic AB
Box 167
S-16329 Spånga
Tel: +46-862-10370
Fax: +46-862-10371

United Kingdom

IXYS UK Sales
Marco Polo House
Cook Way Bindon Road
Taunton, Somerset TA2 6BG
Tel: +44-1-823 352541
Fax: +44-1-823 352797

ASIA / PACIFIC**Asian Headquarters**

IXYS
Room 1016, Chia-Hsin, Bldg II,
10F, No. 96, Sec. 2
Chung Shan North Road
Taipei, Taiwan R.O.C.
Tel: 886-2-2523-6368
Fax: 886-2-2523-6368

IXYS cannot assume responsibility for use of any circuitry other than circuitry entirely embodied in this IXYS product. No circuit patent licenses nor indemnity are expressed or implied. IXYS reserves the right to change the specification and circuitry, without notice at any time. The products described in this document are not intended for use in medical implantation or other direct life support applications where malfunction may result in direct physical harm, injury or death to a person.

Specification: MXJDJ822
©Copyright 2006, IXYS Corporation
All rights reserved. Printed in USA.